

INFLUENCE OF ACTIVITY PATTERNS ON SOCIAL ORGANIZATION OF *MALLOS GREGALIS* (ARANEAE, DICTYNIDAE)

William J. Tietjen¹

Department of Biology
Georgia College
Milledgeville, GA 31061 USA

ABSTRACT

Direct observation of colony behavior indicated that individual *Mallos gregalis* spiders exhibited a change in behavior related to activity level and position in the web. High-activity *M. gregalis* were found on the surface of the web while low-activity animals were found in the web interior. Individuals move to the web surface in the evening and into the web interior at midday. The activity of the colony was recorded through photoelectric means and was circadian with the highest level of activity occurring at night, the lowest level occurring about midday. The circadian rhythmicity was maintained in isolated *M. gregalis* and activity was recorded by similar photoelectric means. The data indicate that isolates fluctuated between high and low activity levels over several days. I suggested that such changes in individual activity level allow each animal to partition its behavior between self-maintenance and colony-maintenance behaviors. In comparing the social structure of *M. gregalis* to other social arthropods, I indicated that the level of organization is more similar to that of tent caterpillars than to the social Hymenoptera.

INTRODUCTION

Only 33 group-living species have been described among the more than 32,000 known species of spiders (for review, see Burgess 1978, Kraft 1970, Kullman 1972, Shear 1970). One such group-living species is the dictynid *Mallos gregalis* (Burgess 1976, Diguët 1915). In the field more than 100,000 animals of both sexes and all stadia live together on one tree (Burgess 1979, Diguët 1909, Uetz, personal communication). Predation and feeding are communal with no cannibalism occurring among conspecifics (Witt et. al. 1978).

Wilson (1971) called groupings of araneids similar in behavior to *M. gregalis* a "pre-social" level of organization. Burgess (1978) avoided the term "social" because *M. gregalis* lack a morphological or ethological caste system. Instead, he described the lifestyle as "communal cooperative".

One feature of communal organization is the circadian rhythms of the group, as measured through the synchrony of activity among group members and the organization of individual's activity cycles (McBride 1976). Circadian activity rhythms have been observed in a variety of araneids (Cloudsley-Thompson 1978). The circadian activity rhythms of non-communal spiders were recently described in *Araneus diadematus* by Ramousse and Davis (1976) and in *Agelenopsis aperta* (Riechert and Tracy 1975). Krafft (1969) showed that activity in colonies of the communal spider *Agelena consociata* was

¹Present address: The Lindenwood College, Department of Biology, Saint Charles, Missouri 63301.

circadian, peaking between 1900 and 2000 hr. Similarly, colony activity of *Cyrtophora citricola* is greatest at night with daytime movements restricted to prey capture and emergency web repair (Rystra 1979). No attempts were reported to record the activity of single animals for either communal spider. The present study is concerned with the activity rhythms and behavior of both isolated and grouped *M. gregalis*. The research was initiated to describe one aspect of the individual's behavior as it contributes to the collective behavior of the colony.

METHODS

General Methods.—*M. gregalis*, from a small colony collected near Guadalajara, Mexico, by J. W. Burgess in 1974, were maintained in a climate-controlled room ($T = 25 \pm 5^\circ\text{C}$, $\text{RH} = 90 \pm 10\%$, 12.5 L: 11.5 D). One large colony occupied a web built on potted plants (*Philodendron* spp.). Numerous smaller colonies built interconnected webs on the walls and among the exposed pipes near the ceiling. Colonies were fed houseflies (*Musca domestica*) at weekly intervals and daily were given a fine spray of water on the web-surface. Experimental animals were collected from the surface of the large web and from the interior of disassembled small colonies.

Direct observations.—Approximately 200 individuals of both sexes and various age classes (mainly subadult and adult females; ca. 4-5 mm body length) were released within a large plexiglass cage (Fig. 1; 91.0 L x 47.0 W x 35.5 H cm). A narrow chamber located near one wall of the cage provided an area where a web was built and facilitated observations of the spider's movements within the interior of the web. The large cage was located in the climate-controlled room and the animals within were cared for in the same way as the large colony located on the table.

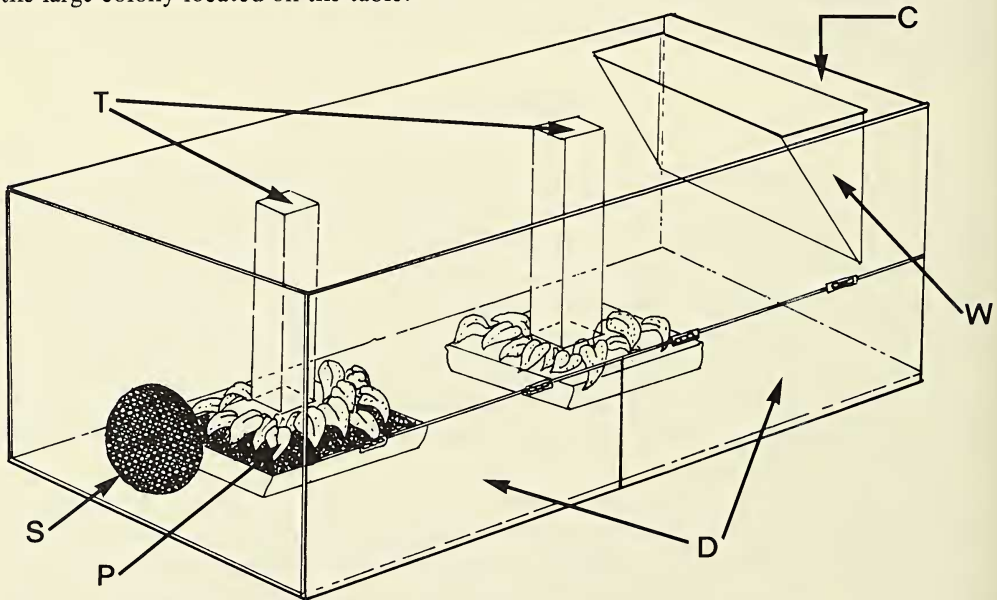

Fig. 1.—Plexiglass cage used for observation of colony behavior. Two screened vents (S, the second vent is located on the rear wall of the apparatus) provided ventilation. Plants (P) provided support for potential web sites. A narrow chamber (C) was formed along one wall by means of a plexiglass wedge (W) and allowed observation of animals in the web-interior. Plexiglass tunnels (T) allowed observations of animals in/on webs built among the plants. Hinged doors (D) allowed for access.

Observation periods were 15 min in length and occurred between 0900 and 1800 hr over a two-week period (12 hr of direct observation). The reduced light intensity and great number of highly active animals (see below) did not permit reliable observations outside of the above 9-hr period. Behaviors were recorded at 15-sec intervals and the position (inside or on the web-surface) was noted for each individual. Those animals in areas that were currently being used as prey-capture sites were scored as occupying the web-exterior.

A second group of 36 adult female and two adult male *M. gregalis* were observed over a two-week period in a smaller plexiglass cage (20.5 x 17.5 x 18.0 cm; 15 hr observation). Lighting was natural for a May day in North Carolina and provided by a nearby window. Temperature was not controlled but was relatively constant at 23°C (the maximum temperature was about 4°C higher at 1600 hr than at the minimum temperature which occurred at 0500 hr). Observation periods were 15 min in length and randomly staggered over the two-week period to provide at least two observation periods per hour. Between 0800 and 1800 hr the numbers of moving and non-moving spiders, their behavior and positions in or on the web were stored in the memory of a microcomputer (programmed as an event recorded) and later transferred to magnetic tape. During the night-hours (1800-0700 hr) a 15 W lamp was adjusted to approximate a moonlit night. However, due to the low level of light available and the large number of active animals, only the position of each animal and level of activity were recorded during the night-hours.

In addition to the above systematic observations, 40-50 hr were spent in less structured observation of the large colony on the table. Most of these observations occurred between 0900 and 2000 hr and only the behaviors of animals on the surface of the web were visible.

Photoelectric recordings.—The activity levels of 50 isolated adult female *M. gregalis* were recorded in activity chambers (Fig. 2). Females were contained in a 40 mm (id) x 170 mm (1) tygon tube forming a toroidal activity chamber (ca. 50 mm dia). The passing of a spider between the phototransistor and light source was recorded on one of 20 channels of an Esterline-Angus event recorder. Further information on this apparatus is

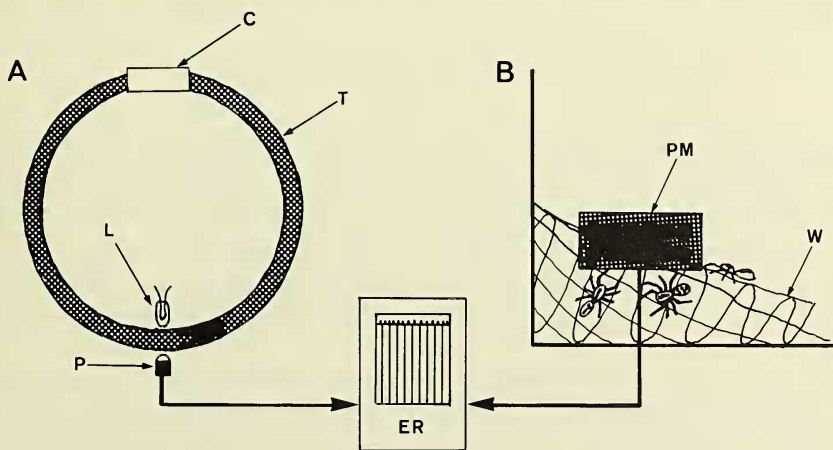

Fig. 2—Photoelectric recording methods. A: Apparatus to measure activity of isolated *Mallos gregalis*. Tygon tubing (T), held end-to-end by a coupling tube (C) contained the animals. Movement of spiders between the phototransistor (P) and biasing lamp (L) was recorded on one channel of an event recorder (ER). Colony activity (B) used a photocell matrix (PM). Movement of spiders on the web (W) was recorded as in A.

available from the author. Animals were provided daily with a drop of water but were not fed during the experiments. Such periods of deprivation are well within the survival limits recorded for a variety of spiders which range from several months to nearly a year (Anderson 1974, Miyashita 1968, Turnbull 1962, 1965, Witt 1963). Photoperiod was approximately 10 L: 13 D and the maximum temperature (0900-1000 hr) was 27°C which decreased to about 22.5°C at 0600 hr. Humidity was not controlled and varied between 70 and 95%.

Following a 24 hr acclimatization period for the females, experiments ran continuously for 9 days. Only those spiders surviving the entire experimental period and an additional day following the experiments were used in the analysis of data (33 animals; most deaths were due to drowning in the water droplet).

The activities of 12 isolated adult female *M. gregalis* were recorded in a similar manner to the above group, except that illumination was continuous over an 11-day period, starting 3 days prior to the 9-day recording period. In these experiments deaths due to drowning were eliminated. One female died from undetermined causes.

The activity of a small colony (74 adult females) was recorded by photoelectric methods in a 20.5 x 17.5 x 18.0 cm plexiglass cage (fig. 2). Twelve phototransistors were arrayed in a 2 x 6 matrix and positioned to record activity occurring mainly on the surface of the web. A 15-W incandescent lamp located 1.5 m from the photosensors provided the biasing source and approximated a bright moonlit night. Movements of the animals were recorded on an event recorder. Krafft (1969), in a similar manner, recorded activity in a small colony (N = 5 individuals) of the colonial spider *Agelena consociata*.

Before recordings began, a 7-day period was provided to allow the spiders to build a web within the cage. Twelve houseflies (*M. domestica*) were fed to the spiders on the last of the 7 days and activity was continuously recorded beginning on the following day for a 12-day period. Environmental conditions were similar to those provided for the isolates. Animals were daily given a fine spray of water on the web-surface.

Statistical analyses were performed according to the methods of Batschelet (1965), Conover (1971) and Sokal and Rohlf (1969). All means are accompanied by their standard errors.

RESULTS

Observations of colony behavior.—Casual observations suggested that, although prey were occasionally pulled into the web-interior and fed upon, communal feeding occurred only on the web-surface. Fecal material was deposited mainly at the edge of the web-surface as evidenced by a ring of droppings on the table and floor surfaces surrounding the web. Few animals were observed on the web-surface during the midday hours, while in the evening or early morning hours the surface was covered with hundreds of active *M. gregalis*.

Since it was not possible to determine the position of all animals during an observation period in the large plexiglass cage, movements between the web-surface and interior were not analyzed. Only the types of behaviors and the active animals' positions are included in this data set and these results are pooled with the data from the small plexiglass cage.

In the small cage, the percentage of animals moving per 15 sec on the web-surface ($\bar{X} = 14.7 \pm 0.4\%$) greatly exceeded movement in the web-interior throughout the day ($\bar{X} = 1.8 \pm 0.1\%$; Mann Whitney test, $p < 0.001$). Movements in the web-interior and on the web-surface were not correlated (Spearman's rho, $\rho = +0.411$, $p < 0.10$). The majority of

animals moved to the web-surface during the evening and returned to the web-interior by midday (Fig. 3; Raleigh test, $p < 0.01$).

Many behaviors were mainly observed in one web-location. Male courtship behavior ($N = 15$) was observed only in the web-interior, as was mating ($N = 5$). All egg sacs were deposited in the interior of the web. The incidence of cribellate silk deposition on the web-surface ($N = 207/15$ -sec intervals) greatly exceeded deposition in the web-interior ($N = 59/15$ -sec intervals; χ^2 test adjusted for animal position, $p < 0.001$). These data were supported by disassembly of webs: silk in the web-interior was compact and non-adhesive while silk on the exterior was adhesive.

Colony activity peaked at 0351 hr \pm 0455 and the lowest activity occurred about midday (Raleigh test; $p < 0.01$ as measured by the photoelectric method and pooled over the experimental period, Fig. 4). These results are consistent with those obtained through direct observations and actographic methods (Tietjen, unpublished data). The mean total events per day was 57.0 ± 8.1 (one event is the movement of an animal between a phototransistor and the source of light) and activity did not vary among days (Wilcoxon test, $p > 0.50$). No trends were observed in the activity level over the experimental period (Spearman's rho, $\rho = +0.14$, $p > 0.10$).

Observations of isolates.—Preliminary observations indicated that the spiders moved freely through the recording area and were not attracted to any one area of the apparatus (including the low-level light used to bias the phototransistors). Those animals recorded as inactive were usually quiescent and did not exhibit behaviors such as silk-deposition outside the field of view of the phototransistor.

The mean movement per animal was 15.7 ± 2.3 events per day. The mean difference between the maximum and minimum daily activity level per animal was 34.0 ± 12.4 events; thus, during days of decreased activity animals typically exhibited little or no movement while days of high activity were characterized by extensive movement. Eight animals exhibited no significant differences in activity over the 9-day period (χ^2 test, $p > 0.05$) while the remaining 25 exhibited a significant difference among days ($p < 0.05$).

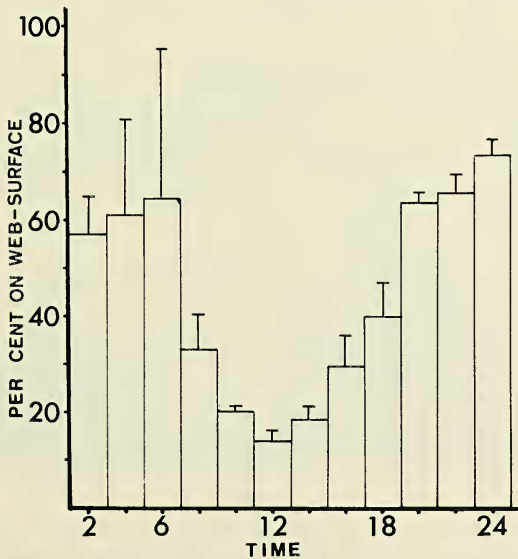

Fig. 3.—Circadian movement between web-areas. The graph indicates the percent animals observed on the web-surface over a 24-hr period (pooled for 2-hr intervals).

The difference in total daily activity compared among spiders varied considerably (χ^2 test, $p < 0.0001$). Only three of the 33 spiders exhibited a positive trend in daily activity level over the 9-day period while no spiders exhibited a negative trend (Spearman's rho, $p < 0.05$ for positive correlation with time). Figure 5 indicates the daily activity level of each animal over the 9-day period. Note that most spiders shift between high and low activity levels over several days.

The total numbers of events per hour were pooled among isolated spiders thus treating the isolates as if they occupied a single colony. Data indicate an activity peak at 0253 ± 0429 hr and a decrease in activity about midday (Fig. 4; Raleigh test, $p < 0.01$). No differences were observed between the activity peaks for the pooled isolates and the colony (F test, $p < 0.10$). The pooled activity of all spiders did not vary among days ($\chi^2 = 519.6 \pm 68.2$ events per day; Kruskal-Wallis test, $p > 0.05$). No correlation was observed between the total events per day and time since recording began (Spearman's rho, $\rho = 0.35$, $p > 0.10$).

Isolates tested under constant-light conditions exhibited a decrease in activity compared to isolates under normal lighting conditions ($\chi^2 = 6.9 \pm 0.5$ events per day; Mann Whitney test, $p < 0.0001$). The daily activity level was too low to test on a day-to-day basis and the data were therefore pooled for further analysis. The greatest activity level occurred at 0.617 hr ± 0428 . This was not significantly different from the activity cycles observed for the colony or isolates under normal lighting conditions (F test, $p > 0.05$).

DISCUSSION

Colony behavior.—The present data indicate that the collective activity levels of individual *M. gregalis* in a colony are highest at night and lowest at midday. Krafft (1969) described a similar circadian activity rhythm in the communal spider *A. consociata* and indicated that the timing of the cycle was influenced by photoperiod. My data, however, offer conflicting evidence. Although the constant-light condition affected the total daily activity level of the isolates, the expected shift in time for peak activity was not observed. This may be due to the necessity of pooling the data over the experimental period or other cues, such as temperature, may also be involved as is the case in solitary spiders (Witt 1963).

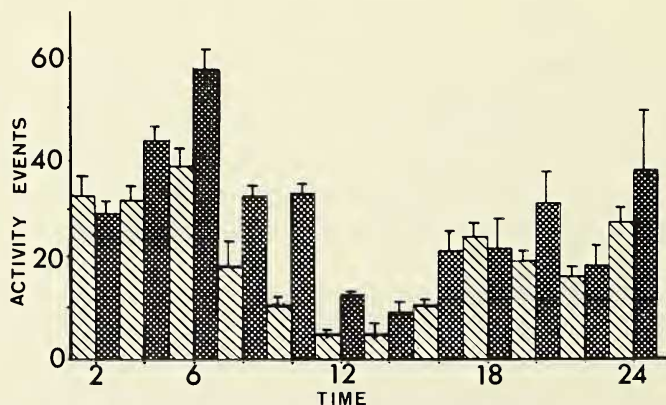

Fig. 4.—Circadian activity of isolated and groups *Mallos gregalis*. Activity of a colony pooled over the experimental period is indicated by the striped bars. The mean activity level of isolated animals pooled among animals is indicated by the hatched bars.

Direct observations indicate that activity level is higher on the web-surface than in the web-interior throughout the day. The spiders did, however, exhibit a circadian rhythmicity in movement between the web areas; occupying the web-surface mainly at night and the web-interior during the day. Animals in the web-interior were typically inactive and the lack of a positive correlation between activity levels in the two areas suggests that, as spiders in the web-interior become active, they move to the web-surface.

In nature, spiders may move to the web-interior to avoid the heat of the noonday sun. Such temperature-dependent movements have been described in the non-communal spider *Agelenopsis aperta* (Richert and Tracy 1975). In addition, by restricting periods of activity in the night hours, *M. gregalis* may effectively avoid visual predators (e.g. birds) as suggested by Rypstra (1979) for the communal spider *Cyrtophora citricola*.

Factors other than activity may have their probability patterns affected by the animal's position on the web. Silk-deposition, communal-feeding, prey capture and fecal-elimination occurred mainly on the web-surface. In contrast to the report of Jackson and Smith (1978), males exhibited courtship behavior only in the web-interior. All matings and deposition of egg sacs similarly occurred only in the web-interior. The web therefore appears to assist in organizing and coordinating the various behaviors of colony members. Alternatively, the animals may organize their behavior spatially and build the web accordingly, however, such an explanation would be applicable only under very restricted conditions. Tietjen (1981) indicated that the webs built by colonies in small containers (petri dishes) tended to be densest near the rim of the dish while colonies built under less confined conditions were highly variable in structure (Hollar, personal communication, Tietjen, unpublished data).

Effects of isolation.—Among the Araneae, there are few studies regarding the effect of group-size on the behavior of the individual. Burch (1977, 1979) investigated the effect of isolation during the early communal life of *Araneus diadematus*, and showed that, although isolates built functional webs, they matured more slowly than spiderlings raised communally. Among the social spiders, isolated mature female *Stegodyphus sarasinorum*

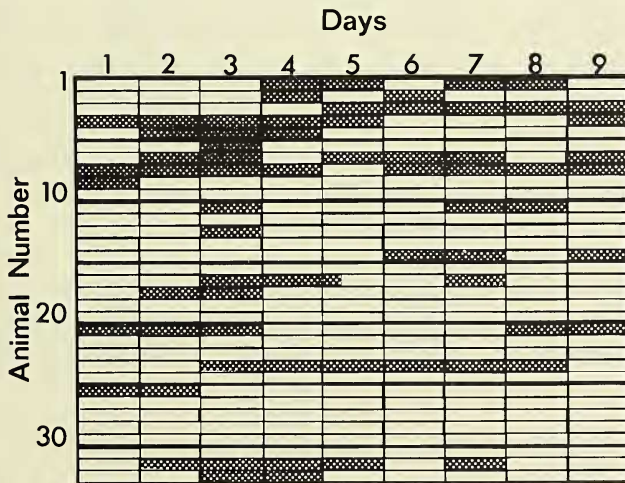

Fig. 5.—Daily activity of isolates. A graphical representation of the day-to-day activity of 33 animals over the 9-day experimental period is presented. Days of an individual's increased activity (number of events per day greater than $\bar{Y} + 1SE$) are indicated by the shaded bars; days of low activity are indicated by unshaded bars.

are less active than conspecifics living communally (Tietjen, unpublished data) and fewer *A. consociata* survive when isolated from nestmates (Krafft 1969).

Mallos gregalis, on the other hand, develop and survive normally when isolated from the colony (Jackson 1979). In addition, individuals often leave the parent colony and produce functional webs. The present data suggest that the circadian activity rhythms of individuals were not affected by isolation since the circadian activity of the colony was similar to the pooled activity of isolates (Fig. 4).

Individual activity patterns and the effect on colony organization.—*M. gregalis* lacks a distinct caste system and all members of the colony perform a variety of tasks related to web-maintenance, web-building, feeding, prey capture and reproduction (Burgess 1976). Coordination of some or all of these tasks may depend on individual activity levels. Individual *M. gregalis* exhibit fluctuations in activity over several days (Fig. 5) and the level of activity affected the spider's position on the web. In addition, the likelihood of certain behaviors occurring was related to web-position. These data suggest that individual activity levels coordinate colony-maintenance vs. self-maintenance behaviors in the communal web. Animals of low activity would be expected to remain in the web-interior; involved mainly in self-maintenance behaviors such as reproduction or feeding on flies drawn into the interior (although the majority of feeding occurs on the catching surface). Animals of high activity would be found on the exterior of the web taking part in colony-maintenance behaviors such as prey-capture and silk-deposition. One might expect that such a system might lead to "cheaters" in which an animal spends most of its time in self-maintenance dedicating little or none of its time budget to colony-maintenance behaviors. Physiological and/or behavioral restraints such as the need to empty silk glands or to move to the surface for feeding may inhibit individuals from becoming cheaters. In

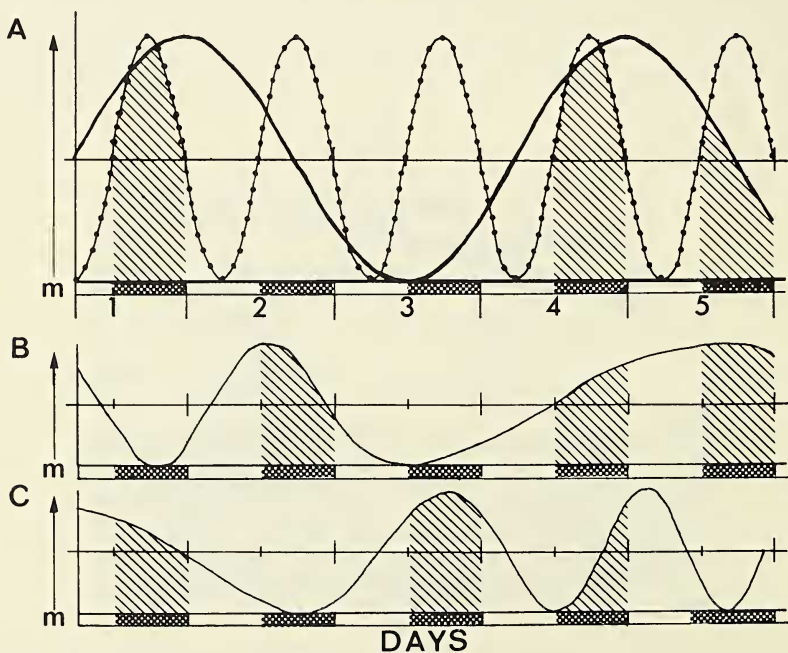

Fig. 6—Individual activity cycles summate and result in constant daily activity levels for the colony. A) The probability of movement (*m*) is affected by the circadian cycle (dotted line) and the individual's cycle (solid line). In this example, high activity occurs on days 1, 4 and 5 (hatched areas). The individual cycles and periods of high daily activity are shown for two additional animals (B, C).

addition, for long-term nest sites one might expect a high degree of relatedness among nest mates allowing kin selection to occur. Such interpretations must, however, await a genetic analysis of a number of natural populations.

The factors which control individual daily activity were not determined. It is unlikely, however, that the level of hunger in these experiments affected total daily activity (at least over the experimental period), as animals were not fed and few trends were observed in total daily activity. Likewise temperature, humidity and photoperiod have little effect on an animal's total daily activity since isolates were tested concurrently and the peaks of high daily activity were out of phase among animals (Fig. 5); these factors may be important in nature as they affect prey density. Endogenous conditions such as sexual tone (Crane 1949) may affect daily activity. Individuals of high sexual tone, for example, would be expected to exhibit low activity and be found mainly in the web-interior.

When the total daily activity among animals was pooled and analyzed day-to-day, the total daily activity of the "statistical colony" did not change over the experimental period even though each animal's contribution to the activity changed over several days (Fig. 5). Likewise, the total daily activity of the colony recorded by photoelectric methods did not change over the experimental period. Figure 6 represents a model of the summation of individual activity cycles and their effect on colony activity. Two cycles are apparent: 1) A circadian cycle shared by all members of the group, cued perhaps by a combination of photoperiod and temperature and 2) an individual cycle, cued by endogenous factors and out of phase among animals. High levels of individual activity are possible only when both cycles are at a peak. Low activity occurs under all other circumstances. With many individuals in a colony, each with their own personal activity cycle, the end result is a total daily colony activity which does not change on a day-to-day basis even though the active participation of individuals changes constantly.

In the tent caterpillar larve (*Malacosoma pluviale*) an analogous situation exists. Individual differences in activity affect the behavior and development of the colony. Larve of high activity tend to emigrate and become leaders of the group while those of low activity are the followers. Individual activity levels does not, however, change from day-to-day but extend throughout adult life. The proportion of active and inactive larve in the colony affects the behavior of the entire group; controlling, for example, the frequency of future infestations and the propensity of the colony to defoliate new areas of the host tree (Wellington 1957).

Among the social Hymenoptera extreme minor-major caste polymorphism, as seen in some species of ants and termites, is accompanied by behavioral specializations which divide the work of the colony according to caste (Wilson 1971). Among the social bees, individual workers have a limited behavioral repertoire; however, individual and age polyethisms allow for efficient foraging among a variety of flower-types (Heinrich 1976). According to the data presented, the organization of colonies of *M. gregalis* is therefore more similar to that of tent caterpillars than to the organization seen in the social Hymenoptera.

ACKNOWLEDGMENTS

I am grateful to Dr. P. N. Witt for many helpful discussions during the course of this research and the preparation of the manuscript. Drs. S. E. Riechert and G. W. Uetz provided helpful comments in the review of the manuscript. The research was supported by National Science Foundation grant BNS 75-09915 to P. N. Witt and W. J. Tietjen and was conducted in the laboratories of the North Carolina Department of Mental Health.

REFERENCES CITED

- Anderson, J. F. 1974. Responses to starvation in the spiders *Lycosa lenta* Hentz and *Filistata hibernalis* (Hentz). *Ecology*, 55:576-585.
- Batshalet, R. 1965. Statistical methods for the analysis of problems in animal orientation and certain biological rhythms. Washington, D. C.: Amer. Inst. Bio. Sci., 57 pp.
- Burch, T. L. 1977. Early communal life of the solitary web spider (*Araneus diadematus* Cl.) Raleigh: Ph.D. Thesis N.C. State Univ., 6-77.
- Burch, T. L. 1979. The importance of communal experience to survival for spiderlings of *Araneus diadematus* (Araneae: Araneidae). *J. Arachnol.* 7:1-18.
- Burgess, J. W. 1976. Social Spiders. *Scient. Am.*, 234:100-106.
- Burgess, J. W. 1978. Social behavior in group-living spider species. *Symp. Zool. Soc. London*, 42:69-78.
- Burgess, J. W. 1979. *Mallos gregalis*-behavioral adaptations for living in Mexico. Raleigh: Ph.D. Thesis N. C. State Univ., 3-20.
- Cloudsley-Thompson, J. L. 1978. Biological clocks in Arachnida. *Bull. Br. Arachnol. Soc.*, 4:184-191.
- Conover, W. J. 1971. Practical nonparametric statistics. New York: John Wiley and Sons, Inc., 492 pp.
- Crane, J. 1949. Comparative biology of salticid spiders at Rancho Grande, Venezuela. Part IV. An analysis of display. *Zoologica*, 34:159-215.
- Diguet, L. 1909. Sur l'araignées mosquero- *Compte Rendu Acad. Sci. Paris*, 148:735-736.
- Diguet, L. 1915. Nouvelles observations sur le mosquero ou nid d'araignées sociales. *Bull. Soc. nat. acclim. France*, 62:240-249.
- Heinrich, B. 1976. Bumblebee foraging and the economics of sociality. *Amer. Sci.*, 64:384-395.
- Jackson, R. R. 1979. Predatory behavior of the social spider *Mallos gregalis*: is it cooperative? *Insectes Soc.*, 26:300-312.
- Jackson, R. R. and S. E. Smith. 1978. Aggregations of *Mallos* and *Dictyna* (Araneae, Dictynidae): Population characteristics. *Psyche*, 85:65-80.
- Krafft, B. 1969. Various aspects of the biology of *Agelena consociata* Denis when bred in the laboratory. *Amer. Zool.*, 9:201-210.
- Krafft, B. 1970. Contribution á la biologie et á l'éthologie d'*Agelena consociata* Denis (Araignée social du Gabon). *Biol. Gabon*, 6:199-301.
- Kullman, E. J. 1972. Evolution of social behavior in spiders (Araneae: Eresidae and Theridiidae). *Amer. Zool.*, 12:419-426.
- McBride, G. 1976. The study of social organization. *Behavior*, 59:96-115.
- Miyashita, K. 1968. Quantitative feeding biology of *Lycosa T-insignata* Boes. et Str. (Araneae: Lycosidae). *Bull. Nat. Inst. Agric. Sci., Ser. C.*, 22:329-334.
- Ramousse, R. and F. Davis III. 1976. Web-building time for a spider: preliminary application of ultrasonic detection. *Physiol. Behav.*, 17:997-1000.
- Riechert, S. E. and C. R. Tracy. 1975. Thermal balance and prey availability: basis for a model relating web-site characteristics to spider reproductive success. *Ecology*, 56:265-284.
- Rypstra, A. L. 1979. Foraging flocks of spiders. *Behav. Ecol. Sociobiol.*, 5:291-300.
- Shear, W. A. 1970. The evolution of social phenomena in spiders. *Bull. Br. Arach. Soc.*, 1:65-76.
- Sokal, R. R. and F. J. Rohlf. 1969. *Biometry*. San Francisco: W. H. Freeman, 766 pp.
- Tietjen, W. J. 1981. Sanitary behavior by the social spider *Mallos gregalis* (Dictynidae): Distribution of excreta as related to web density and animal movements. *Psyche* (in press).
- Turnbull, A. L. 1962. Quantitative studies of the food of *Linyphia triangularis* Clerck (Araneae: Linphiliidae). *Canadian Ent.*, 94:1233-1349.
- Turnbull, A. L. 1965. Effects of prey abundance on the development of the spider *Agelenopsis potteri* (Blackwall) (Araneae: Agelenidae). *Canadian Ent.*, 97:141-147.
- Wellington, W. G. 1957. Individual differences as a factor in population dynamics: the development of a problem. *Canadian J. Zool.*, 35:293-323.
- Wilson, E. O. 1971. *The Insect Societies*. Cambridge, Mass.: Harvard Univ. Press, 548 pp.
- Witt, P. N. 1963. Environment in relation to behavior of spiders. *Arch. Environ. Health*, 7:4-12.
- Witt, P. N., M. B. Scarboro, and D. B. Peakall. 1978. Comparative feeding data in three spider species of different sociality: *Araneus diadematus* Cl., *Mallos trivittatus* (Banks) and *Mallos gregalis* (Simon). *Symp. Zool. Soc. London*, 42:89-97.